

Chapter 1 Review 1  
Show All Work

Name \_\_\_\_\_  
Period \_\_\_\_\_ Date \_\_\_\_\_

1) The table shows the number of calories burned by a person participating in various types of exercise for a given time period. How many more calories are burned biking for 60 minutes than playing racquetball for 40 minutes?

Exercise	20 minutes	40 minutes	60 minutes
Roller Blading	196	391	587
Biking	125	251	376
Racquetball	169	341	510
Rowing	108	217	325
Soccer	164	331	495
Baseball	162	323	485

---



---

2) Did the Eagles or the Rockets win more games in January?  
How many more games did they win?

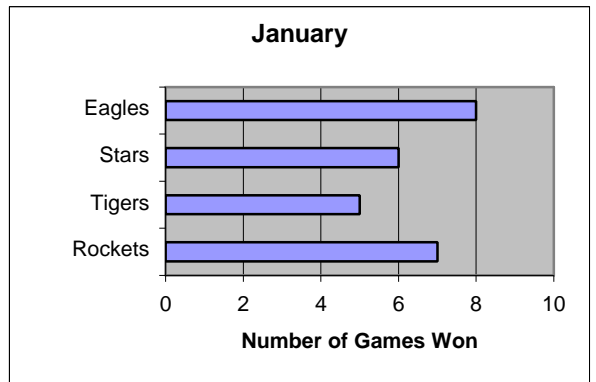

---



---



---

3) Translate and evaluate:

a) The quotient of 60 and 4

b) The product of 9 and 3

4) Evaluate the variable expression for the given values:

$$6a - b \quad \text{when} \quad a = 7, \quad b = 14$$

5) Evaluate  $x^3$  when  $x = 5$

6) Find the perimeter of the given rectangle.

7) Find the area of the same rectangle.

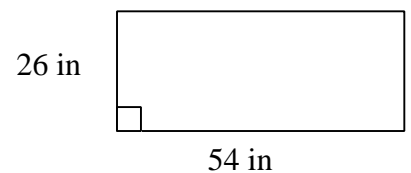

8) Find the perimeter of the given geometric shape.

9) Find the area of the same shape.

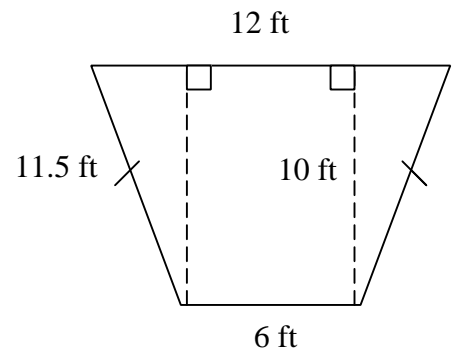

Chapter 1 Review 1 (con't)

- 10) You want to fertilize a *rectangular* piece of garden that measures 40 feet by 35 feet. If each bag of fertilizer covers 75 square feet, how many bags of fertilizer will you need to buy? (Hint: you can't buy a partial bag of fertilizer.)

**Problems 11 to 13: Use order of operations to evaluate.**

- 11)  $15 \cdot 6 \div 3^2 - 5 + 4^2$                       12)  $12 \div 3 \cdot 4 + 14 - 9$                       13)  $2^3 [12 - 4(2 \cdot 4 - 3) \div 2]$

For the sequence 1, 4, 9, 16, \_\_\_\_, \_\_\_\_, \_\_\_\_

- 14) Describe the pattern. \_\_\_\_\_  
15) Fill in the next three numbers. \_\_\_\_\_  
16) Use the distributive property to write equivalent expressions. Then simplify.  
a)  $7(3y - 9)$                       b)  $12(c + d + e)$                       c)  $8(3x^2 + 4x - 2)$   
17) *Factor* the following expressions to write equivalent expressions.  
a)  $5x - 30$                       b)  $7y + 28$                       c)  $4y - 14$

**For problems 18 to 22: Given the following examples,**

$5(9 \cdot 2) = (5 \cdot 9)2$ ;  $7 + 1 = 1 + 7$ ;  $(2 + 7) + 4 = 2 + (7 + 4)$ ;  $3(2y - 6) = 3 \cdot 2y - 3 \cdot 6$ ;  $8 \cdot 4 = 4 \cdot 8$

- 18) Which represents the Commutative Property of multiplication? \_\_\_\_\_  
19) Which represents the Associative Property of multiplication? \_\_\_\_\_  
20) Which represents the Commutative Property of addition? \_\_\_\_\_  
21) Which represents the Associative Property of addition? \_\_\_\_\_  
22) Which represents the Distributive Property? \_\_\_\_\_  
23) Hamburger costs \$1.75 per pound. Steak costs \$3.50 per pound. If Mary purchases 6 pounds of hamburger, what will be the total cost?  
a) Identify the irrelevant information.  
b) Solve the problem.

Use distributive property, then simplify.

- 24)  $8(x^2 + 5x + 2) - 5x^2 - 3x - 9$                       25)  $6(3y + 5) + 7(y + 9) - 10y - 60$